

**PLAN VIEW**  
(Scale = 2x)

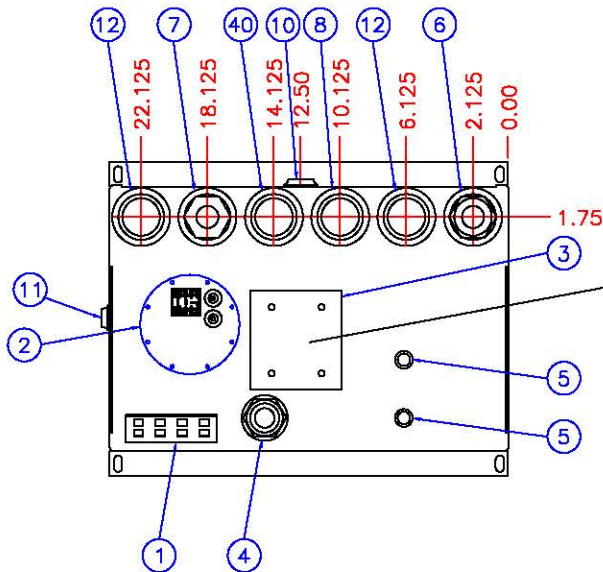

NOTE - PUMP & MOTOR NOT SHOWN IN ORDER TO REVEAL TANK OPENINGS

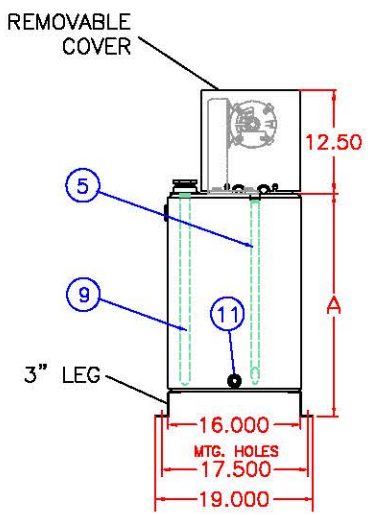

LEFT SIDE VIEW

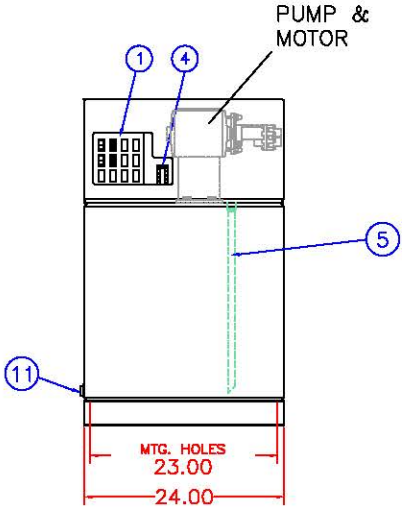

FRONT VIEW

**TANK DIMENSION REFERENCE CHART**  
(SHOWN IN INCHES)

TANK RATED CAPACITY	A - HEIGHT (TANK SIZE)	U/L VENT NPT SIZE	WEIGHT * BASIC TANK	WEIGHT * U/L LISTED TANK
10 GAL.	15.50	2.00	125 LBS	128 LBS
15 GAL.	21.50	2.00	144 LBS	148 LBS
25 GAL.	26.50	2.00	160 LBS	164 LBS

\* Approximate Weight - Includes Pump, Motor & Related Controls (No Options)

**REF# DESCRIPTION OF STANDARD EQUIPMENT**

1	CONTROL PANEL
2	6-1/2" X 6-1/2" INSPECTION PLATE
3	6" x 6" MOTOR MOUNTING PLATE
4	1-1/2" NPT - FUEL LEVEL GAUGE
5	FUEL INLET/OUTLET TO/FROM TANK w/DROP TUBES
6	2" x 1" NPT - ENGINE FUEL SUPPLY w/DROP TUBE
7	2" x 1" NPT - ENGINE FUEL RETURN w/DROP TUBE
8	2" NPT - TANK VENT TO ATMOSPHERE
9	1" NPT - DROP TUBES for ENGINE SUPPLY & RETURN
10	1" NPT - OVERFLOW TO MAIN STORAGE TANK
11	1/2" NPT - TANK DRAIN w/DROP TUBE (PLUGGED)
12	2" NPT - EXTRA CONNECTION

**ADDITIONAL EQUIPMENT IF TANK IS U/L LISTED**

40	NPT CONNECTION FOR U/L EMERGENCY RELIEF VENT (See Above Chart For Size)
----	---

**CONSTRUCTION NOTES**

- 1 - TANK TOP, BOTTOM, & SHELL - 12 GAUGE STEEL
- 2 - DIMENSIONS SUBJECT TO CHANGE WITHOUT NOTICE

**STANDARD SINGLE WALL DAY TANK**  
PY10 - PY25  
PY10UL - PY25UL (U/L Listed Version)



DRAWN BY: <i>RES</i>	DATE: 03/01/2008
CHECKED BY: <i>D/W</i>	REV: 03/01/2008
SHEET NO. 1 of 1	DWG #: <b>STD_SW_A</b>