

PLAN VIEW
(SCALE: 1.5X)

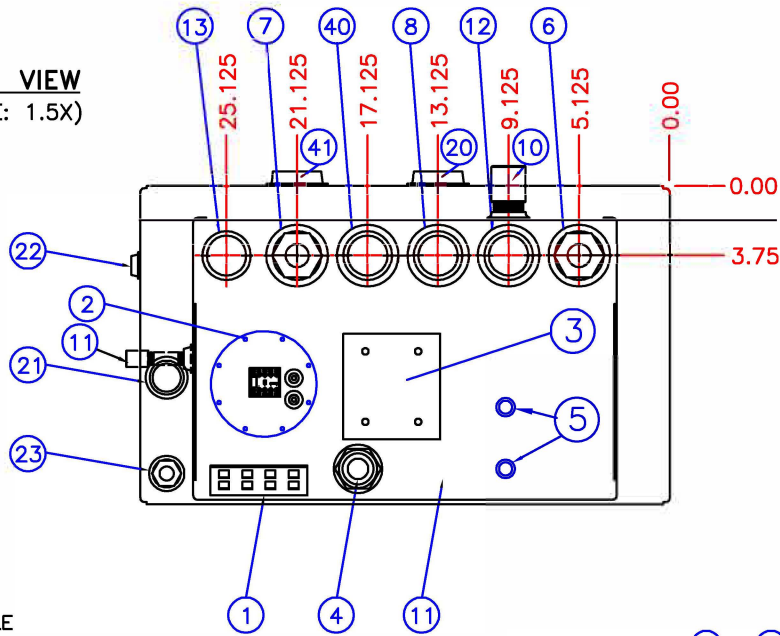

REMOVABLE COVER

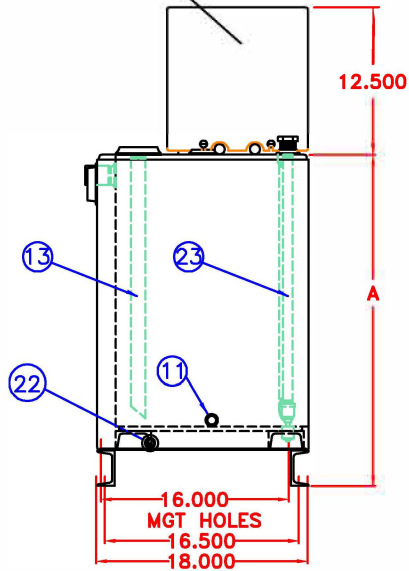

LEFT SIDE VIEW

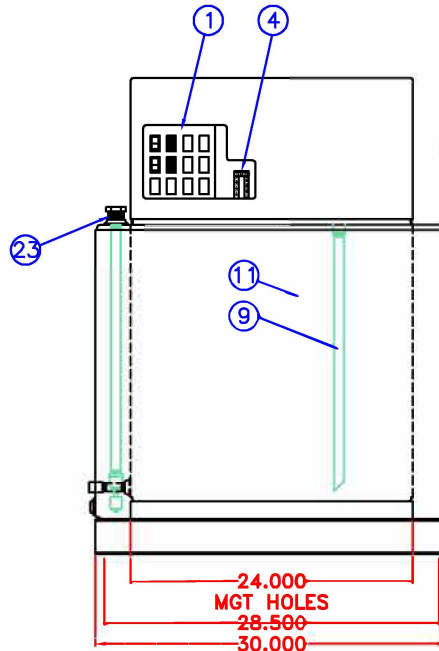

FRONT VIEW

TANK DIMENSION REFERENCE CHART
(SHOWN IN INCHES)

TANK RATED CAPACITY	A - HEIGHT * (TANK SIZE)	U/L VENT NPT SIZE	WEIGHT * BASIC TANK	WEIGHT * U/L LISTED TANK
10 GAL.	17.00	2.00	195 LBS	200 LBS
15 GAL.	23.00	2.00	234 LBS	239 LBS
25 GAL.	28.00	2.00	267 LBS	271 LBS

* Approximate Weight (No Options)

REF# DESCRIPTION OF STANDARD EQUIPMENT

1	CONTROL PANEL
2	6-1/2" X 6-1/2" INSPECTION PLATE
3	6" x 6" MOTOR MOUNTING PLATE
4	1-1/2" NPT - FUEL LEVEL GAUGE
5	FUEL INLET/OUTLET TO/FROM TANK w/DROP TUBES
6	2" x 1" NPT - ENGINE FUEL SUPPLY w/DROP TUBE
7	2" x 1" NPT - ENGINE FUEL RETURN w/DROP TUBE
8	2" NPT - TANK VENT TO ATMOSPHERE
9	1" NPT - DROP TUBES for ENGINE SUPPLY & RETURN
10	1" NPT - OVERFLOW TO MAIN STORAGE TANK
11	1/2" NPT - TANK DRAIN w/DROP TUBE (PLUGGED)
12	2" NPT - EXTRA CONNECTION
13	2" NPT - MANUAL FILL w/DROP TUBE
20	2" NPT - VENT TO ATMOSPHERE for DOUBLE WALL SECONDARY CONTAINMENT AREA
21	1-1/4" NPT - INSPECTION PORT for DOUBLE WALL SECONDARY CONTAINMENT AREA
22	3/8" NPT - Drain for DOUBLE WALL SECONDARY CONTAINMENT AREA
23	1/2" NPT - For OPTIONAL LEAK DETECTOR (NOT SUPPLIED) for DOUBLE WALL SECONDARY CONTAINMENT AREA

ADDITIONAL EQUIPMENT IF TANK IS U/L LISTED

40	NPT CONNECTION FOR U/L EMERGENCY RELIEF VENT (See Above Chart For Size)
41	NPT CONNECTION FOR U/L EMERGENCY RELIEF VENT for DOUBLE WALL SECONDARY CONTAINMENT AREA

CONSTRUCTION NOTES

- TANK TOP, BOTTOM, & SHELL - 12 GAUGE STEEL
- DIMENSIONS SUBJECT TO CHANGE WITHOUT NOTICE

MANUAL DOUBLE WALL DAY TANK
PY10MDW - PY25MDW
PY10MULDW - PY25MULDW (U/L Listed Version)



PRYCO, INC.
MECHANICSBURG, ILLINOIS

DRAWN BY: RES | DATE: 03/01/2008
CHECKED BY: DTW | REV: 03/01/2008
SHEET NO. 1 of 1 | DWG #: MAN_DW_A